



# Steel Track Paver RP-2505

#### ENGINE

Tier 3, Caterpillar® C6.6 174 hp (130 kW) @1,800 rpm

#### OPERATING WEIGHT

Tractor Weight: 42,230 lbs (19,155 kg)

#### SCREEDS

- 2.55 Dual Tamper Screed: 9,656 lbs (4,380 kg)
- 2.55 Single Tamper Screed: 9,100 lbs (4,128 kg)



# FEATURES



## Overview: RP-2505

The RP-2505 is a powerful 8' (2.5 m) steel-tracked paver built to operate with high-density tamper bar screeds. Visibility, maintenance access, and operator comfort highlight the RP-2505. The dual ComfortDrive™ operator stations can move hydraulically beyond the sides of the machine for excellent visibility. The standard FXS® fume extraction system draws the fumes from the rear auger and away from the operator area. The versatile RP-2505 is capable of achieving high densities in stiffer mixes such as cold mix, base materials and roller compacted concrete as well as conventional hot mix asphalt.

## Frame

Roadtec pavers start with an extremely strong frame completely fabricated, welded, and assembled by Roadtec. With 0.75" (19 mm) thick continuous side sheets and a 4" (102 mm) thick front cross frame member, this machine has a very durable and reliable foundation.

## TTS-2550—Rear Extendable Dual Tamper Bar Screed

The TTS-2550 is an 8'4" (2,540 mm) hydraulically extendable screed with integral rear mounted extensions that allow a maximum paving width of 16'8" (5,080 mm). Dual tampers with variable front stroke and fixed rear tamper stroke allow the screed to achieve high densities in thick layers or with stiff materials such as heavily polymer modified asphalt or roller compacted concrete. Dual screed controls, and thermostatically controlled screed temperatures allow for smooth operation.

## STS—Rear Extendable Single Tamper Bar Screed

The STS-2550 is an 8'4" (2.55m) hydraulically extendable screed with integral rear mounted extensions that allow a maximum paving width of 16'8" (5.1m). Single tamper with variable stroke and fixed rear tamper stroke allow the screed to achieve higher densities in thick layers or with stiffer materials such as polymer modified asphalt. Dual screed controls, and thermostatically controlled screed temperatures allow for smooth operation.

# Options

## Miscellaneous

- Tunnel & auger extension package

## Truck Hitch

- Controls rollers that engage to truck's wheels (replaces push rollers)

## Lubrication

- Automated lubrication system

## Additional Lighting

- Night light package- Six 24v HID Lights
- Airstar® balloon light assembly- 500W halogen bulbs, fan, telescoping pole, two brackets and case

## Screed Automation

- MOBA® sonic grade and slope control
- TOPCON® sonic grade and slope control

## Feed System

The RP-2505 feed system is designed to maximize production while maintaining durability and mat quality. Chromium carbide wear plates, dual offset link conveyor chains, and 16" (406 mm) cast ni-hard augers are in place to withstand the wear and tear of the paving operation. The auger assembly can be hydraulically raised, tilted, and lowered. The augers can also be operated independent of the feeders to better manage head of material and combat material segregation. Standard sonic feeders control each side of the feed system. Electric flow gates are also standard on the machine.

## Tracks

The 11.8" (300 mm) wide steel tracks with durable polyurethane track pads provide excellent maneuverability, traction and weight distribution for the RP-2505.





# SPECIFICATIONS

## ENGINE

- Tier 3, Caterpillar® C6.6 174 hp (130 kW) @1,800 rpm

## WEIGHTS

- Tractor Weight.....42,230 lbs (19,155 kg)
- 2.55 Dual Tamper Screed .....9,656 lbs (4380 kg)
- 2.55 Single Tamper Screed .....9,100 lbs (4,128 kg)

## CHASSIS

- .75" (19 mm) thick continuous side sheets.
- 4" (102 mm) thick front cross frame member.
- Oscillating push rollers.

## ELECTRICAL SYSTEM

- Two 4D batteries. & 110 Amp alternator.
- 24v system with master disconnect switch.
- Electric-over-hydraulic solenoids with manual override.
- 34 kW hydraulic driven generator.

## COOLING SYSTEM

- Low noise, variable speed, hydraulically-driven fan.

## PROPEL SYSTEM

- Variable-displacement hydraulic pumps.
- Two-speed hydraulic motor. Direct hydraulic, single speed planetary final drives.
- Single joystick control

## SPEED

- Paving speed: 0-104 fpm (32 m/min)
- Travel speed: 0-2.4 mph (3.9 k/hr)

## BRAKE SYSTEM

- Hydrodynamic and parking brake.

## UNDERCARRIAGE

- 11.8" (300 mm) wide Steel tracks with polyurethane track pads
- (8) sets of rollers
- Grease track tension system.

## OPERATOR STATIONS

- (2) hydraulically rotating Comfort Drive™ operator stations. Operator stations can rotate out past edge of machine for increased visibility. All controls rotate with the seat.
- Armrest Comfort Drive™ finger tip paver function control with Total Control joystick (all tractor propel controls on single joystick).

## FUME EXTRACTION SYSTEM

- FXS® fume extraction system

## FRONT HOPPER

- 14.3 ton (13 mt) / 236 ft<sup>3</sup> (6.7 m<sup>3</sup>) capacity. Self-dumping.

## FEED SYSTEM

- Independently-driven, variable-speed feeder conveyors
- 650 BHN center chromium carbide clad conveyor plates. Bolt free design. Sonic feeder control system
- Cast, 16" (406 mm) dia., 0.75" (19 mm) thick, ni-hard augers. Hydraulically raise, lower and tilt auger assembly.
- Electric flow gates for easy control of head of material

## SERVICE CAPACITY

- Full Tank..... 86 gal (324 l)
- Hydraulic Fluid Tank..... 69 gal (262 l)
- Cooling System ..... 7.4 gal (28 l)

## TAMPER BAR SCREEDS: TTS-2550 & STS-2550

- 8'4" (2,540 mm) to 16'8" (5,080 mm) hydraulically extendable screed with integral rear mounted extensions. 20" (508 mm) long, 1/2" (12.5 mm) thick 400 BHN screed plate.
- Standard tamper angle: 55 degrees
- Electric screed heat provided by continuous duty

## STROKE

- TTS-2550: Dual Tampers with variable front stroke 0-11 mm and rear tamper stroke fixed at 5 mm with heat.
- STS-2550: Single Tampers with variable stroke 0-11 mm with heat.

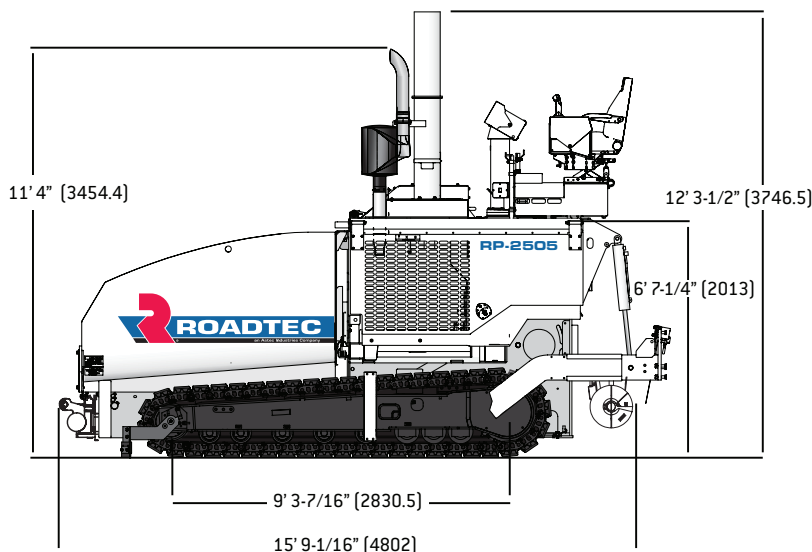

Dimensions in brackets are mm.

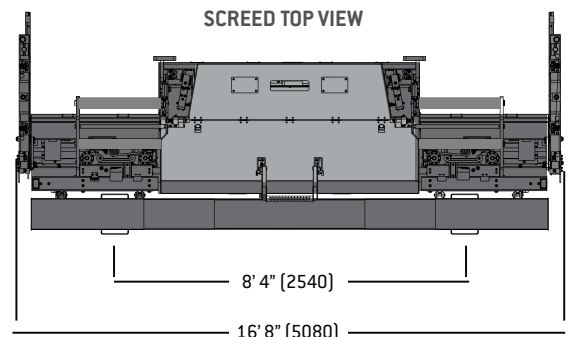

Specifications are subject to change without notice.

## ROADTEC an Astec Industries Company

800 MANUFACTURERS RD • CHATTANOOGA, TN 37405 USA • 800.272.7100 • FAX 423.267.7104 • roadtec.com

130307

© 2013 Roadtec, Inc. All Rights Reserved

